

BENCH INSTRUCTIONS

BC1130
BC1154
BC1158
BC1164

REV# 1

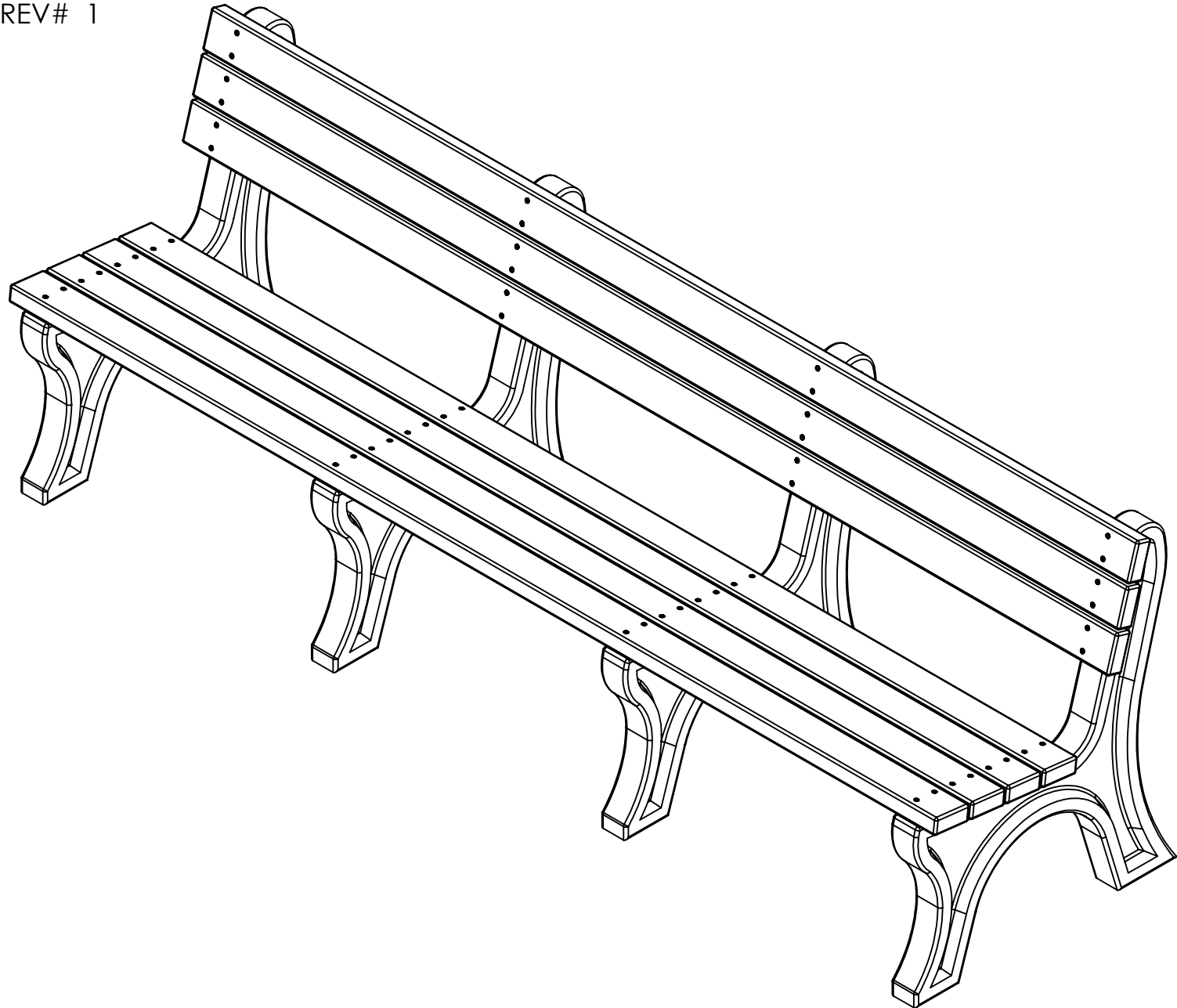

BENCH INSTRUCTIONS

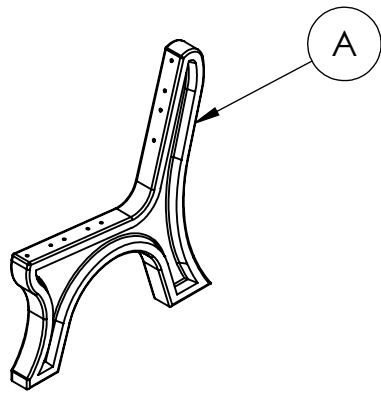

4
BENCH END
ABC-PPL1000

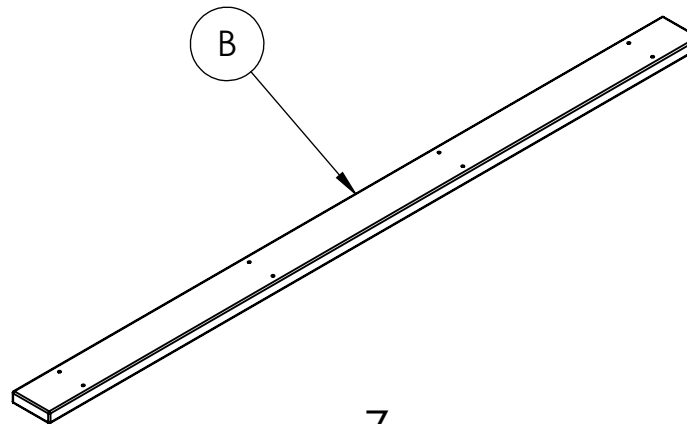

7
PLASTIC BOARDS
ABC-P0098

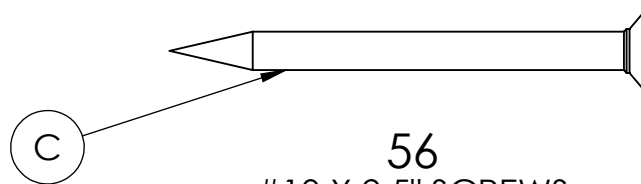

56
#10 X 2.5" SCREWS

**REQUIRED TOOLS
(NOT INCLUDED)**
- POWER DRILL

**NOTE: IT IS IMPORTANT TO KEEP ALL SCREWS LOOSE
DURING ASSEMBLY UNTIL ENTIRE BENCH IS ASSEMBLED**

**HARDWARE &
TOOLS REQUIRED
FOR ASSEMBLY**

2/5

BENCH INSTRUCTIONS

STEP 1 Seat Assembly

- Stand two outer bench ends (A) upright
- Lay a plastic board (B) over the bench ends (A) closest to the end
- Align the holes in the plastic board with the predrilled holes in the bench ends
- Secure the board with the #10 x 2.5" screws (C)
- Repeat for each plastic board starting at the front seat board and working toward the back

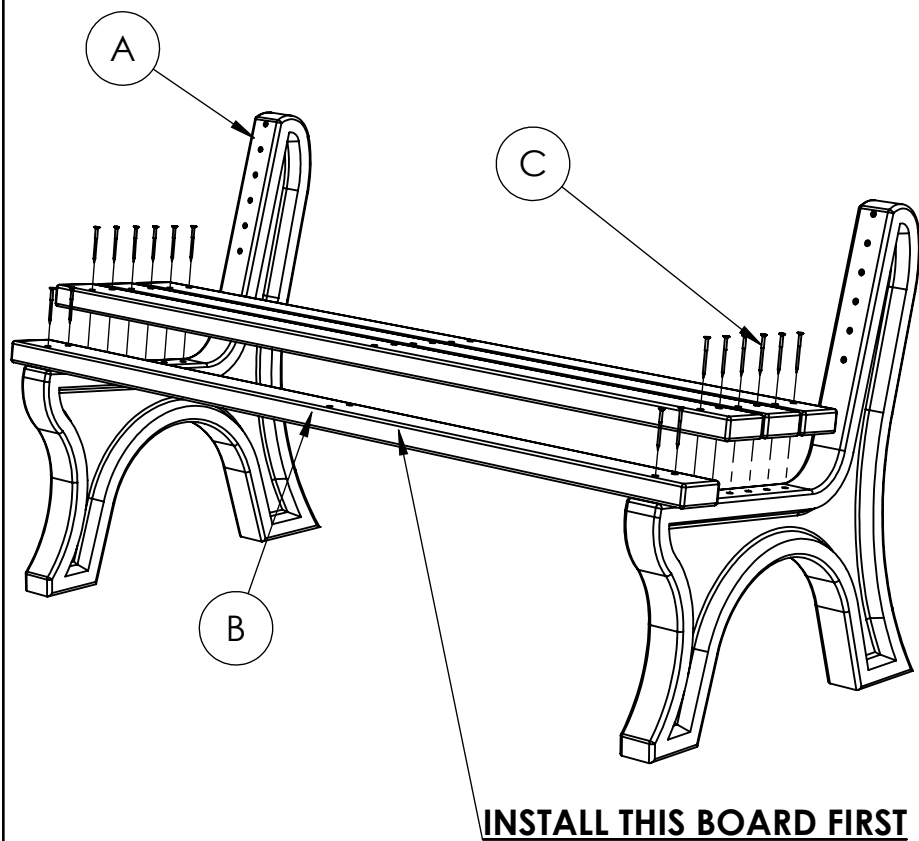

STEP 2 Seat Assembly

- Move the remaining bench ends (A) under the bench seat
- Align the predrilled holes in the bench ends with holes in the plastic board (B)
- Secure each plastic board to the bench ends with #10 x 2.5" screws (C)

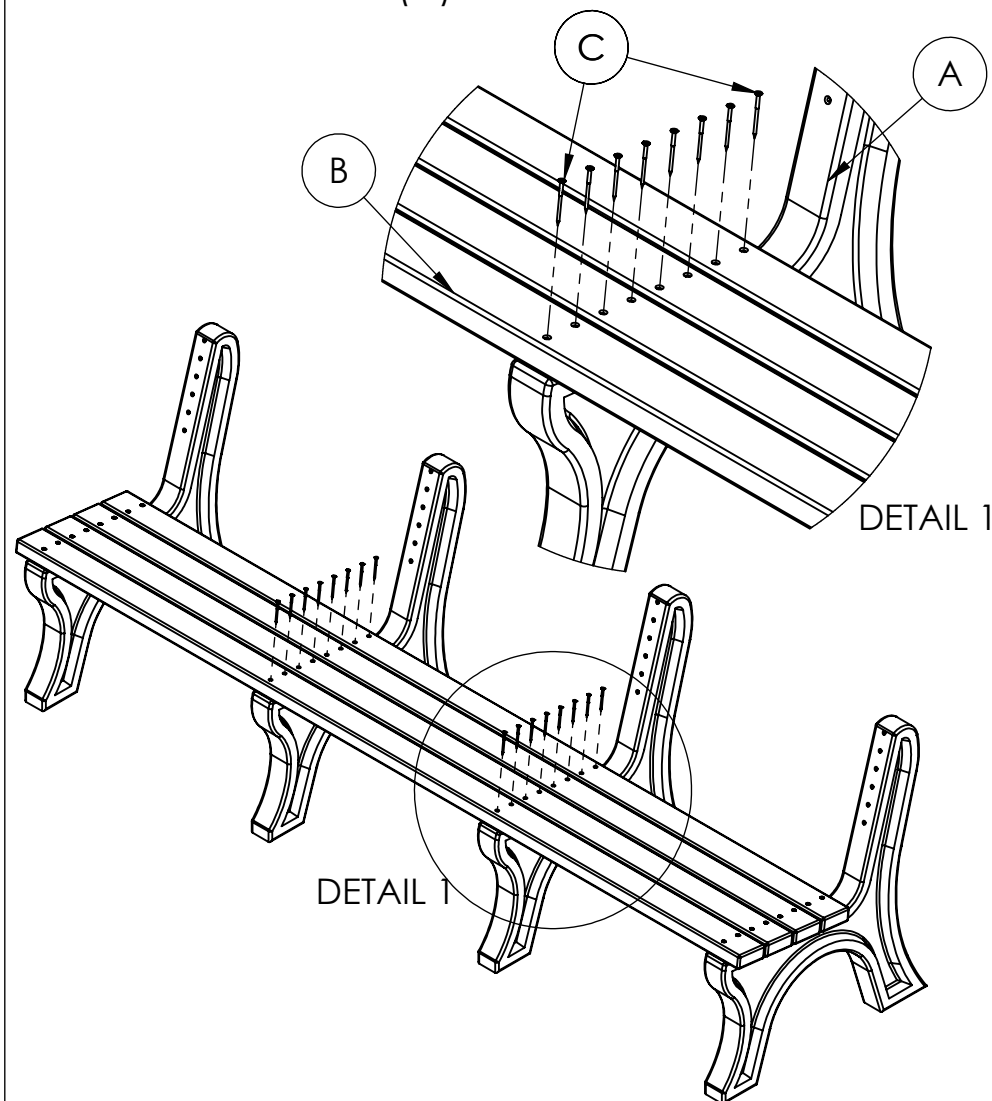

BENCH INSTRUCTIONS

STEP 3 Backrest Assembly

- Hold a plastic board (B) up to the back rest portion of the bench end (A)
- Align the predrilled holes in the bench end (A) with holes in the plastic board (B)
- Secure each plastic board to the bench end with #10 x 2.5" screws (C)
- Square all components and tighten all screws
- Level board and leave 1/4" spacing between boards and secure to bench ends

Note: If there are engraved boards, holes may be missing or not line up properly with bench ends

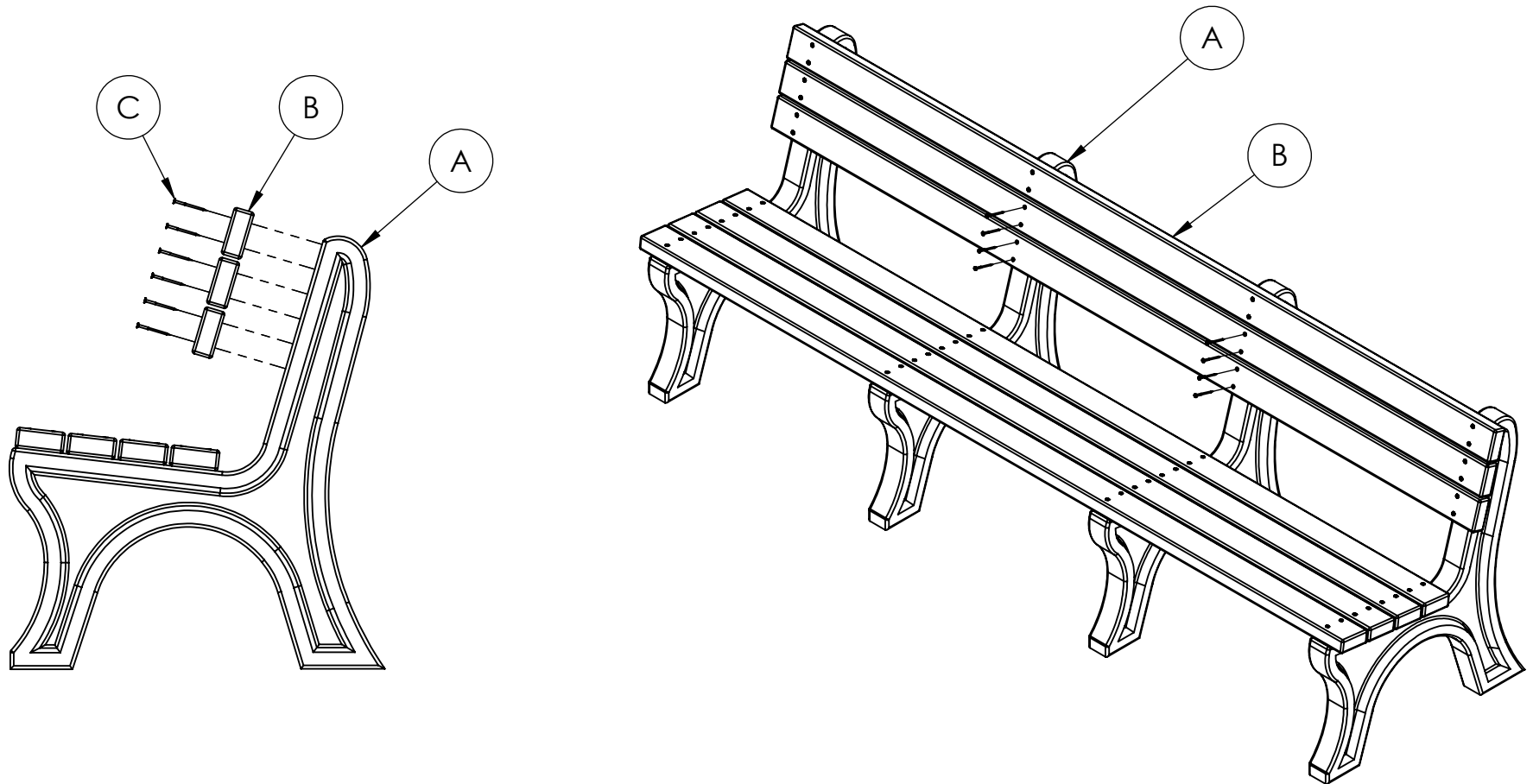

BENCH SPECIFICATIONS

TOP

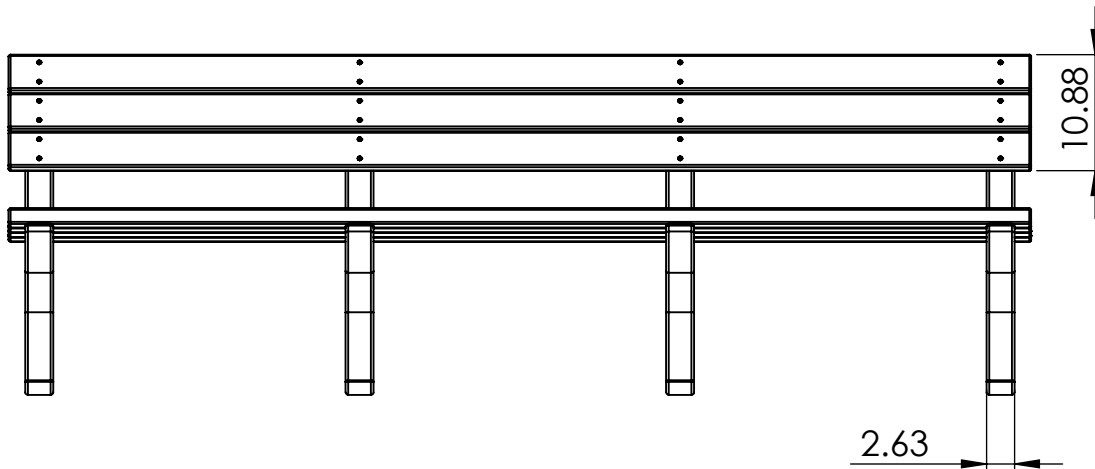
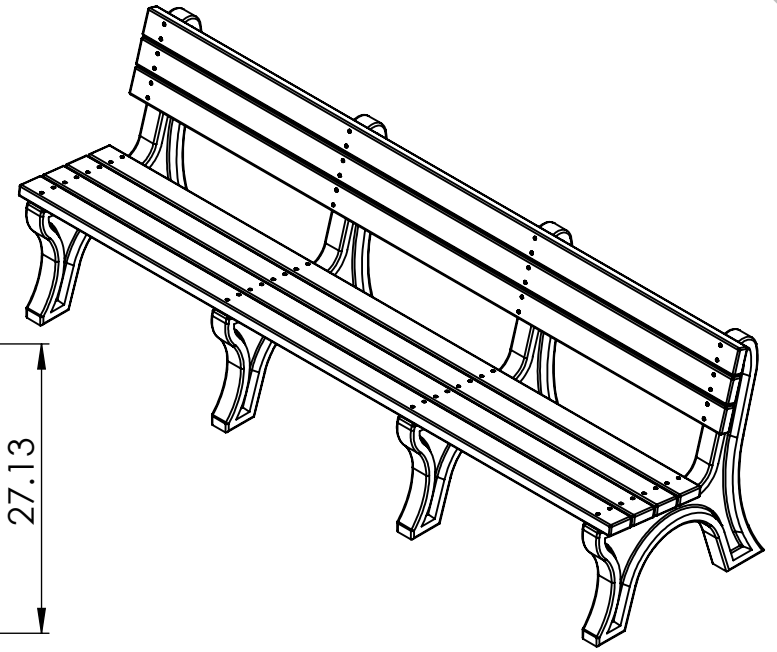
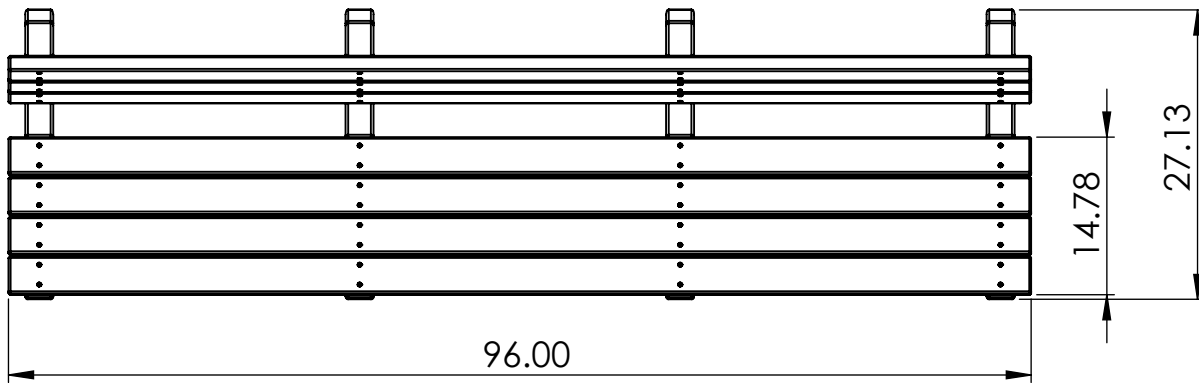

FRONT

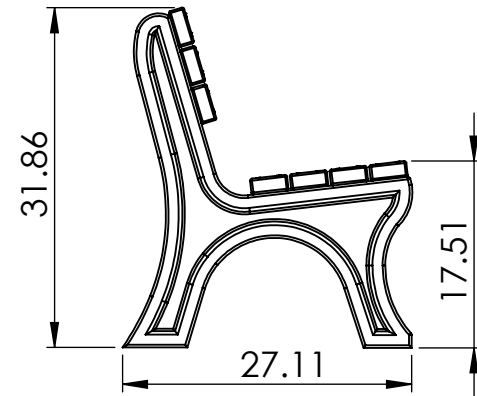

SIDE

CONSTRUCTION MATERIALS:
Recycled Plastic
HARDWARE:
Stainless Steel

ALL DIMENSION SHOWN IN INCHES